

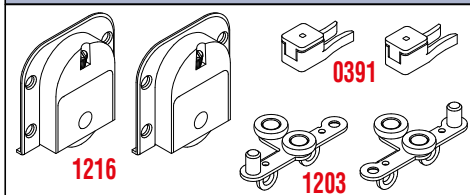

## KIT 1203-1216 - MAX 60 KG

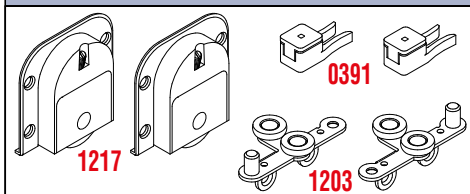

## KIT 1203-1217 - MAX 60 KG



### Legenda KIT / Kit Legend

<b>1203</b>	Guida superiore DX-SX <i>Upper runner left-right</i>
<b>1216</b>	Carrello inferiore regolabile con rullo <i>Lower adjustable truck with roller</i>
<b>1217</b>	Carrello inferiore regolabile con cuscinetto <i>Lower adjustable truck with ball bearing</i>
<b>0391</b>	Fermo superiore <i>Upper stopper</i>

### Legenda altri componenti Legend other items

<b>1200</b>		Profilo alluminio superiore <i>Upper aluminium profile</i>
<b>1210</b>		Profilo alluminio inferiore <i>Lower aluminium profile</i>
<b>1224</b>		Profilo maniglia alluminio (per spessore 18 mm.) <i>Aluminium handle profile (for thickness 18 mm.)</i>
<b>1240</b>		Profilo maniglia alluminio (per spessore 16 mm.) <i>Aluminium handle profile (for thickness 16 mm.)</i>
<b>1221</b>		Guarnizione plastica (per ART.1222 e ART.1224) <i>Plastic profile (for ART.1222 and ART.1224)</i>

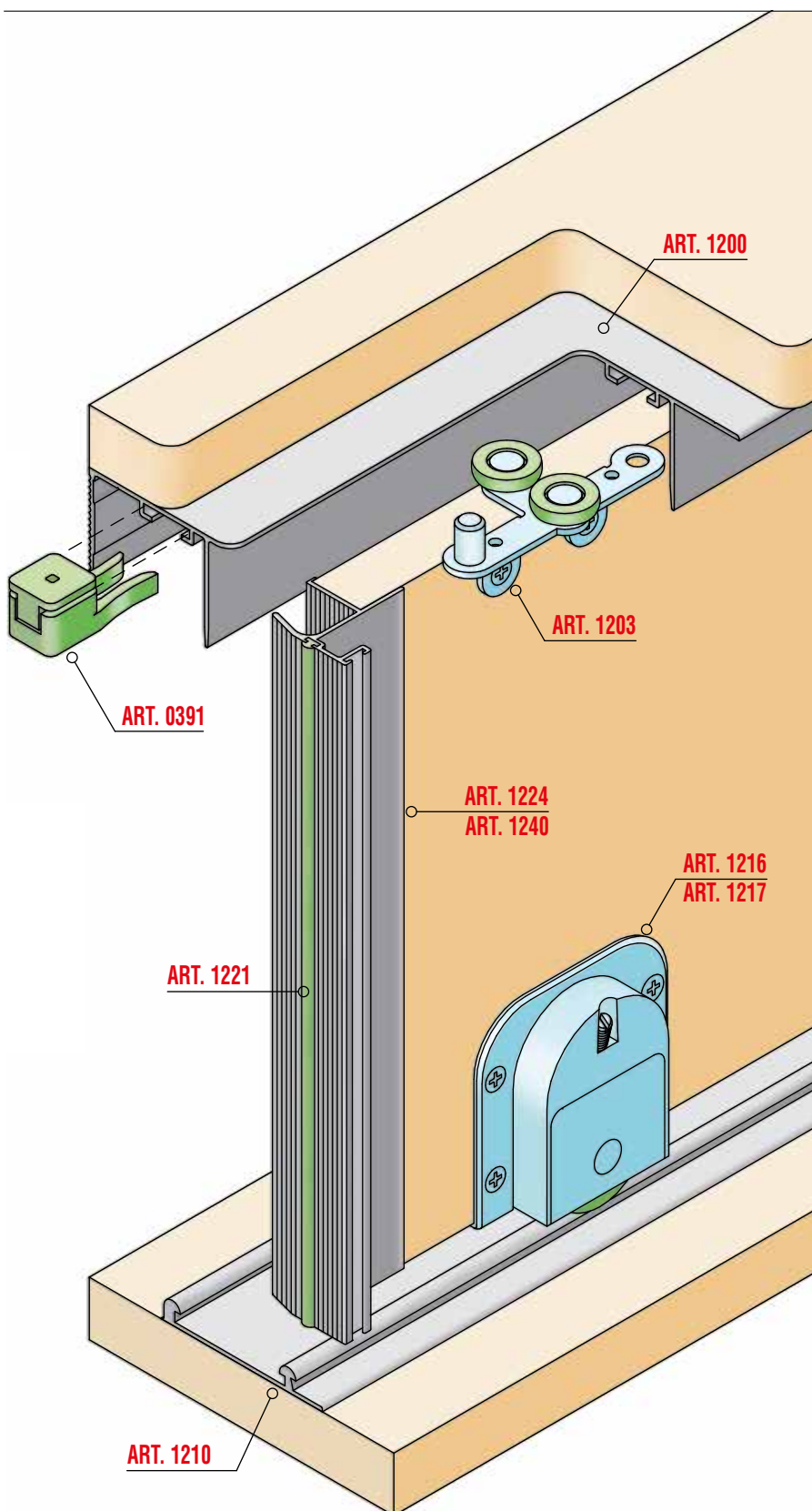





## Schema foratura profili maniglia / Drilling handle profile

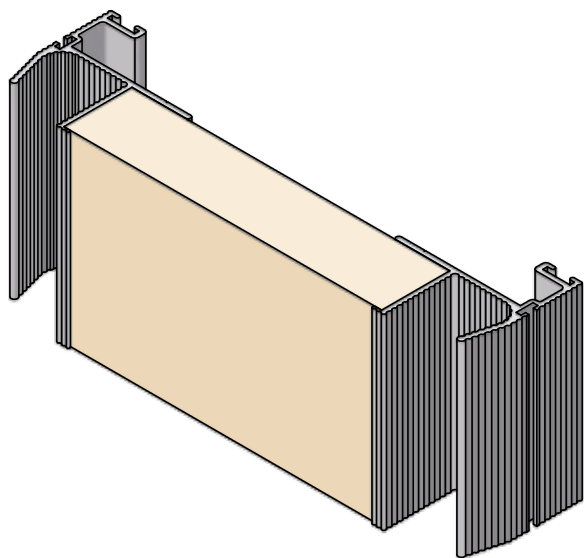

PROFILO MANIGLIA ART.1224 - HANDLE PROFILE ART.1224

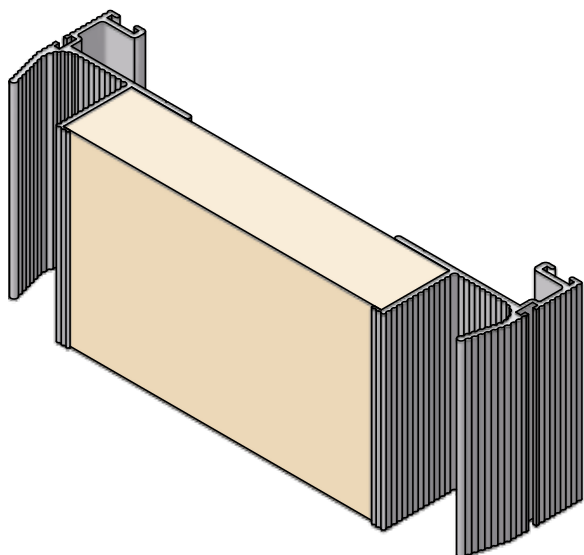
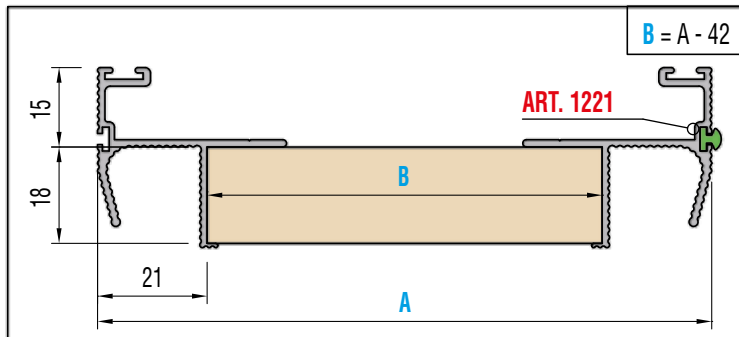

PROFILO MANIGLIA ART.1240 - HANDLE PROFILE ART.1240

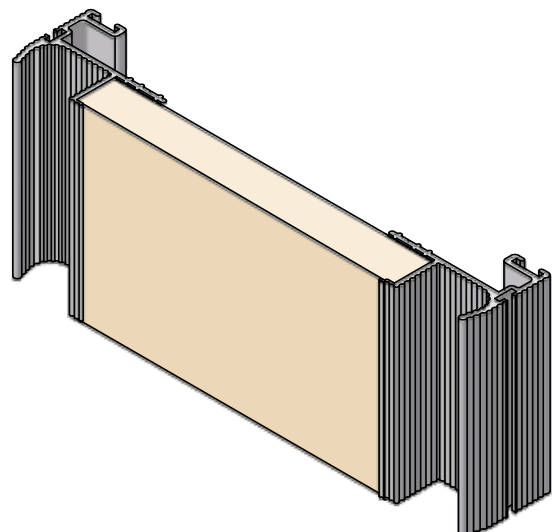
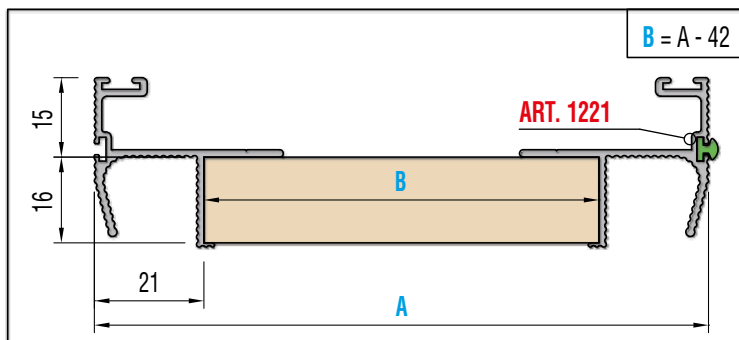

PROFILO MANIGLIA ART.1222 - HANDLE PROFILE ART.1222

